

## Agilent TPS Turbo Pumping Systems

- 2-3 Features and Benefits
- 4-5 Mini-TASK AG81
- 6-7 TPS-compact
- 8-10 TPS-mobile and TPS-bench



The Measure of Confidence



Agilent Technologies



Agilent  
TPS-com

Vacuum Pr

# Agilent TPS Turbo Pumping Systems Features and Benefits

## The New Agilent TPS Family

The new TPS Turbo Pumping Systems: just plug and pump!

Portable, fully integrated vacuum solutions, available as light dry bench-top solutions, for small and medium volumes, or high capacity, wide pumping speed range cart versions.

Now available with the innovative TwisTorr Turbo Pumps. The new molecular-drag technology offers the highest pumping speed and compression ratio.

### Turbo Pumping Systems: basic features

- Integrated, complete vacuum systems
- Wide range from bench-top to cart versions
- Versatile: broad choice of gauges, valves and components
- Compact and portable: small footprint, light weight
- Enhanced, reliable vacuum performances
- Easy-to-use, cost-effective solutions
- Worldwide power configurations and safety standards
- Global Technical, Application and Order Processing support
- Advance Exchange, Upgrade and Repair programs available
- **Dry versions: no hydrocarbon contamination, no oil leaks**



### TPS-compact: Unique IDP-3 Dry Scroll Pump

- The most compact and light scroll pump in the market.
- Innovative hermetic design, with motor and bearings outside the vacuum space.
- Integrated pump isolation valve.
- Cost effective and easy tip-seal replacement.



### TPS-compact/Mini-TASK AG81 Active Gauge Capability

- FRG-700 Active Full Range combined gauge: Pirani and Cold Cathode from atmosphere to  $5 \times 10^{-9}$  mbar ( $7 \times 10^{-9}$  Torr).
- Pressure data available on three independent channels:
  - Serial communication
  - Analog output
  - The gauge can be connected/disconnected from the TPS-compact / Mini-TASK during normal operation.



# TPS Turbo Pumping Systems



## TPS-compact / Mini-TASK AG81 On Board Direct Pressure Reading

- Large pressure reading display.
- Torr, Pascal and mbar options.
- 110 or 220 V, 50/60 Hz.
- I/O and serial interface.
- T-Plus Navigator software to connect to your PC.

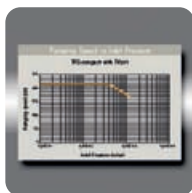

## TPS-compact: Improved Vacuum Performance

- To pump from Atm down to  $10^{-9}$  mbar (Torr).
- Highest pumping speed and compression ratio for  $H_2/He$ .
- Very high foreline pressure tolerance.
- Very high throughput.



## Unique Agilent Turbo Pump Technology

- Innovative TwisTorr molecular-drag technology.
- No maintenance required: Agilent Turbo Pumps don't need oil refills.
- Higher compression ratio and pumping speed.
- Wide pumping speed range from 46 to 700 l/sec.



## TPS-bench & TPS-mobile

Powered by Agilent Turbomolecular pumps and backed by dry scroll or rotary vane pumps.

- TPS-bench: table-top, compact solutions.
- TPS-mobile: roll-around cart, high capacity systems.
- Customized solutions on request.



## Dry Scroll Pumps

- No maintenance required, simple tip seal replacement.
- CE, UL/CUL, CSA and Semi S2-0200 certified.
- Isolation valve integrated/included.
- IDP-3: the smallest scroll pump in the market; peak pumping speed  $3.0 \text{ m}^3/\text{h}$ , and ultimate pressure  $3.3 \times 10^{-1}$  mbar.
- SH-110: peak pumping speed  $5.4 \text{ m}^3/\text{h}$ .
- TriScroll 300 and 600: pumping speed up to  $30 \text{ m}^3/\text{h}$  (TS 600).



## Worldwide Service and Support

- Global network of professional sales and application engineers.
- Toll free telephone lines with native language representatives.
- Technical/Application/Order Processing/Engineering Support.
- Advance Exchange, Upgrade and Repair programs available.



## Rotary Vane Pumps

- Wide pumping speed range from 1.8 to  $20.5 \text{ m}^3/\text{h}$ .
- Dual stage.
- Forced oil circulation.
- Gas ballast valve.
- Anti-suckback valve and vent device.

# Agilent TPS Turbo Pumping Systems Models

## Agilent Mini-TASK AG81

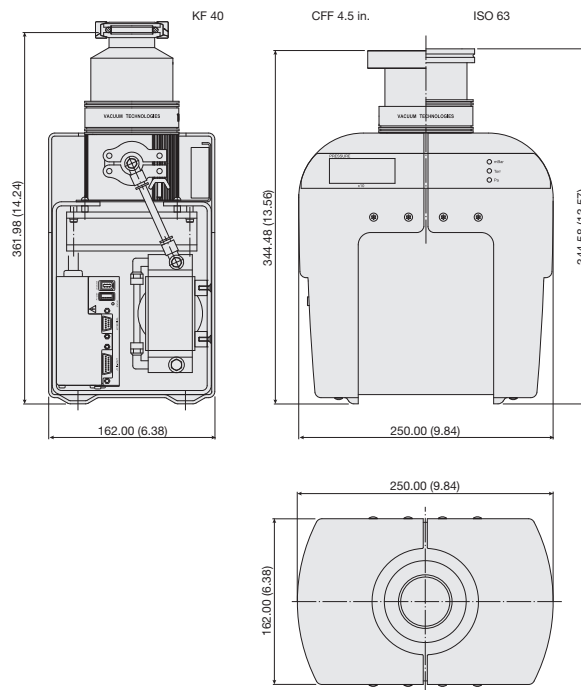

A small and compact, easy-to-use, integrated dry vacuum system, featuring the Agilent Turbo-V 81 MacroTorr pump with improved vacuum performance, backed by a dry 10 l/min diaphragm pump. Operability in any position, no maintenance required. Active Gauge capability, large pressure display, T-Plus Navigator Software to connect to your PC. Universal voltage (90V/240V), CE/CSA certified.

Dimensions: millimeters (inches)

### Features

- New generation turbomolecular pump Turbo-V 81-M
- Compact, light, dry, clean and robust system
- Universal voltage (90 V/240 V) - CE/CSA certified
- RS-232 or analogical communication
- High vacuum gauge driving card
- Large pressure data display
- Pressure driven set point, analog set point

### Benefits

- Designed for demanding applications
- Cost-effective pumping solution for small volumes
- Can be used world-wide
- Easy to use: plug and play system
- Compatible with world-wide power configurations
- Complies with world-wide safety standards
- Easy system pressure measurement

### Technical Specifications

Product Name		KF40	ISO63	CFF 4.5 in.
Pumping speed (l/s)	N2	40	60	60
	H2	36	40	40
	He	45	55	55
Base pressure		$2 \times 10^{-7}$ mbar	$2 \times 10^{-7}$ mbar	$5 \times 10^{-8}$ mbar*
Bakeout temperature		80 °C at inlet	80 °C at inlet	120 °C at inlet
Shipping weight		7.5 kg (16.4 lbs)	7.5 kg (16.4 lbs)	8.3 kg (18.3 lbs)
Pumpdown time (1 liter volume)		60 sec. to 24 mbar; 120 sec. to $1 \times 10^{-4}$ mbar; 160 sec. to $7 \times 10^{-5}$ mbar		
Turbo pump rotational speed		80,000 rpm		
Start-up time		Less than 2 minutes		
Operating position		Any		
Operating ambient temperature		5 °C to 35 °C / 32 °F to 122 °F		
Input Voltage and frequency		90V to 240V AC; 50 Hz / 60 Hz		
Maximum input power		220 VA		
Serial communications		RS-232 cable, 9-pin D-type male, 9-pin D-type female, T-Plus Navigator Software		

\* According to standard DIN 28 428.



# TPS Turbo Pumping Systems

**Pumping Speed VS Inlet Pressure**

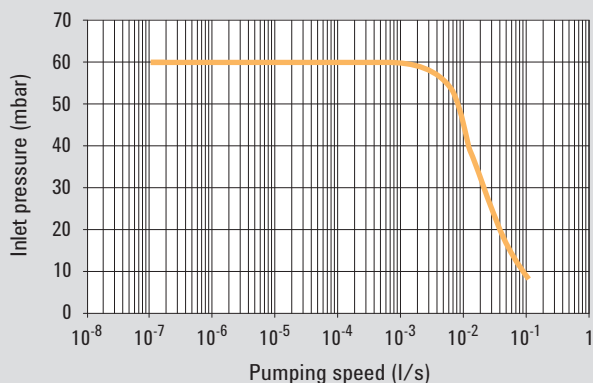

**Pressure VS time (with a pump down vol. of 1 lt.)**

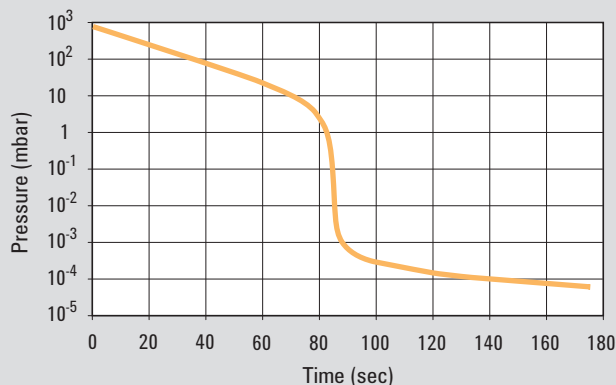

## Applications

- **Electron Microscopy and Mass Spectrometry**

The new Mini-TASK AG81 Integrated Turbo Pumping System is the perfect tool to keep the column of an electron microscope under vacuum while performing maintenance or repair on the device.

The oil-free nature of the system guarantees freedom from contamination of the column.

- **High Energy Physics and Research Centers**

This new Turbo Pumping System may be used in any laboratory where there is a need to create high vacuum in small-volume chambers quickly and easily. It performs best when evacuating volumes of 10 liters or less.

The new generation electronics and the pressure display ensure the accuracy of the process.

- **Semiconductor Manufacturing**

The Mini-TASK AG81 is particularly well suited for evacuating load-lock chambers. Its oil-free design ensures the purity of the process.

The Mini-TASK AG81 may be mounted in any position, making it suitable for most system configurations.

- **Industrial Applications**

The Mini-TASK AG81 Turbo Pumping System can create and maintain the required vacuum level in separate chamber of an industrial system during maintenance or repair.

- **Medical Applications**

Medical accelerators for cancer therapy.

## Ordering Information

Mini-TASK AG81	KF40	ISO63	CFF 4.5 in
	9699180	9699181	9699182
<b>Accessories</b>			
DIY Full Range Gauge Kit*	9699190	9699192	9699193
EU plug power cable**, 2 meters (1 ph)	9499396	9499396	9499396
USA plug power cable**, 2 meters (1 ph)	9499397	9499397	9499397
UK plug power cable**, 2 meters (1 ph)	9499398	9499398	9499398
Serial Cable and T-Plus Navigator Software	9699883	9699883	9699883

**NOTE** Special Vent Valve available on request

\* The DIY Gauge Kit can be ordered separately, and includes Full Range Gauge FRG-700, Cable for gauge connection, Vacuum Tee and Connecting Hardware (Flanges according to the System inlet flange)

\*\* Power Cord to be ordered separately

# Agilent TPS Turbo Pumping Systems Models

## Agilent TPS-compact

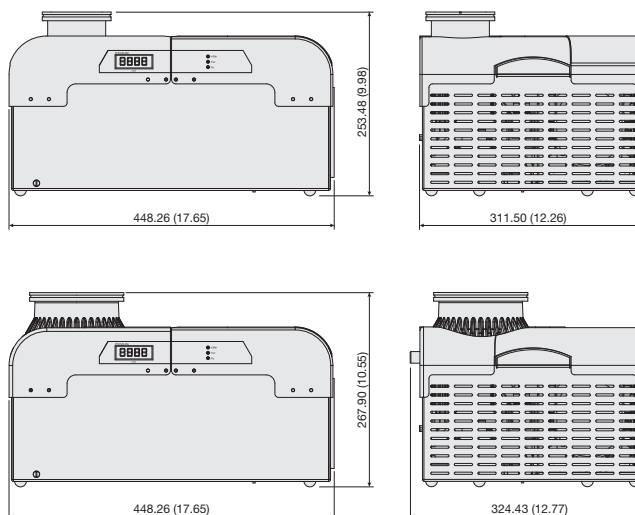

Dimensions: millimeters (inches)

A portable, fully Integrated, hydrocarbon-free pumping system powered by the Turbo-V 81 MacroTorr or Turbo-V 301 Navigator pumps, backed by the unique Agilent 60 l/min IDP-3 Dry Scroll, new generation primary pump. A cost-effective pumping solution with large pressure display, Active Gauge capability, voltage 110-220 V, CE/CSA certified.

### Features

- New generation Turbomolecular Pump Turbo-V 81-M and TV301 Navigator
- Compact, light, dry, clean and robust system
- Voltage (110-220) - CE/CSA certified
- RS-232 or analogical communication
- High vacuum gauge driving card
- Large pressure data display
- Pressure driven set point, analog set point
- IDP-3 Dry Scroll backing pump
- This product can be offered with wheels

### Benefits

- Designed for demanding applications
- Cost-effective pumping solution
- Can be used world-wide
- Easy to use: plug and play system
- Complies with world-wide safety standards
- Easy system pressure measurement
- Easy Tip-seal replacement (10 min)
- Excellent base pressure up to  $10^{-9}$  mbar
- Easy to be moved in small space
- Highest compression ratio for  $H_2/He$

### Technical Specifications

	Equipped with TV81M	Equipped with TV301
<b>Pumping speed</b>	$N_2$ : 77 l/s	$N_2$ : 250 l/s
<b>Base pressure</b>	$1 \times 10^{-9}$ mbar* (CFF flanges) - $1 \times 10^{-8}$ mbar (ISO flanges)	$1 \times 10^{-9}$ mbar* (CFF flanges) - $1 \times 10^{-8}$ mbar (ISO flanges)
<b>Pumpdown time</b> (14 lt volume)	80 sec (100 mbar); 110 sec (1 mbar); 155 sec ( $1^{-4}$ mbar); 400 sec ( $1^{-5}$ mbar)	80 sec (100 mbar); 110 sec (1 mbar); 155 sec ( $1^{-4}$ mbar); 230 sec ( $1^{-5}$ mbar)
<b>Turbo pump rotational speed</b>	80,000 RPM	56,000 RPM
<b>Start-up time</b>	15 sec.	15 sec.
<b>Operating ambient temperature</b>	5 °C to 35 °C	5 °C to 35 °C
<b>Input Voltage and frequency</b>	115 Vac 60 Hz or 220-240 Vac 50/60 Hz	115 Vac 60 Hz or 220-240 Vac 50/60 Hz
<b>Maximum input power</b>	260 VA	310 VA
<b>Bakeout temperature</b>	120 °C at inlet (CFF flanges) - 80 °C at inlet (KF/ISO flanges)	120 °C at inlet (CFF flanges) - 80 °C at inlet (ISO flanges)
<b>Communication</b>	RS232 - Analogical I/O	RS232 - Analogical I/O
<b>Weight</b>	16.7 kg (36.8 lbs)	19.1 kg (42.1 lbs)

\* According to standard DIN 28 428.

# TPS Turbo Pumping Systems

**Pumping Speed vs Inlet Pressure - TV 81M (DN 63)**

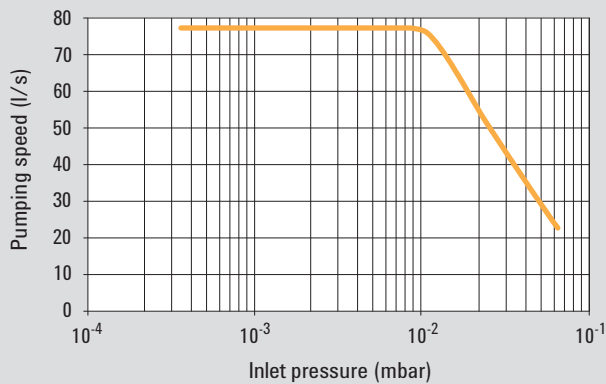

**Pumping Speed vs Inlet Pressure - TV 301 (DN 100)**

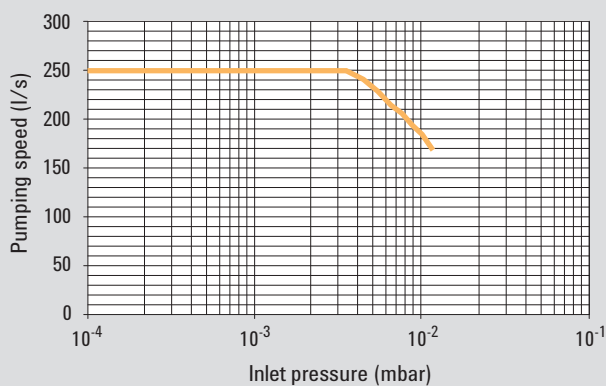

**Pressure vs Time (with a pump down vol. of 14 lt.)**

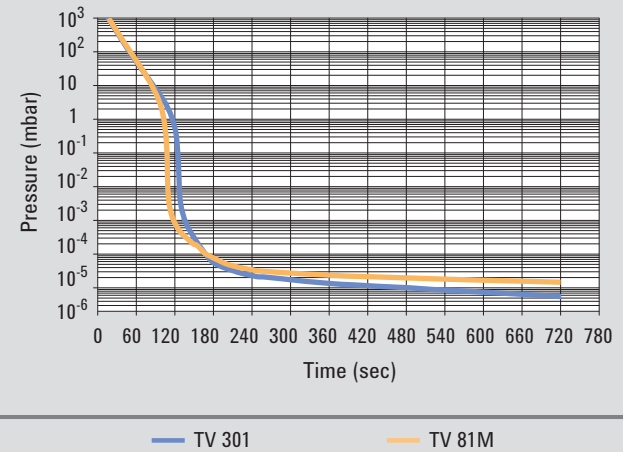

## Ordering Information

Wheels accessory kit	9698233
EU Power cable (2 m)	9499396
US Power cable (2 m)	9499397
UK Power cable (2 m)	9499398
EU Power Cord (5 m)	9698450
US Power Cord (5 m)	9698452
UK Power Cord (5 m)	9698451
Serial Cable and T-Plus Navigator Software	9699883

## Applications

- Electron Microscopy and Mass Spectrometry**  
 The new TPS-compact Integrated Turbo Pumping System is the perfect tool to keep the column of an electron microscope under vacuum while performing maintenance or repair on the device.  
 The oil-free nature of the system guarantees freedom from contamination of the column.
- Industrial Applications**  
 The TPS-compact Turbo Pumping System can create and maintain the required vacuum level in separate chamber of an industrial system during maintenance or repair.

- Semiconductor Manufacturing**  
 The TPS-compact is particularly well suited for evacuating load-lock chambers. Its oil-free design ensures the purity of the process.  
 The TPS-compact may be mounted in any position, making it suitable for most system configurations.
- High Energy Physics and Research Centers**  
 This new Turbo Pumping System may be used in any laboratory where there is a need to create high vacuum and ultra high vacuum in chambers quickly and easily.  
 The new generation electronics and the pressure display ensure the accuracy of the process.

## Ordering Information

TPS-compact	TV81M KF40	TV81M CFF 2.75"	TV81M ISO 63	TV81M CFF 4.5"	TV301 ISO 100	TV301 CFF 6"	TV301 ISO 160	TV301 CFF 8"
120 V	9698217	9698218	9698219	9698220	9698221	9698222	9698223	9698224
220 V	9698225	9698226	9698227	9698228	9698229	9698230	9698231	9698232

### Accessories

DIY Full Range Gauge Kit*	9699190	9699199	9699192	9699193	9699194	9699201	9699195	9699202
---------------------------	---------	---------	---------	---------	---------	---------	---------	---------

**NOTE** Special Vent Valve available on request

\* The DIY Gauge Kit can be ordered separately, and includes Full Range Gauge FRG-700, Cable for gauge connection, Vacuum Tee and Connecting Hardware (Flanges according to the System inlet flange)

# Agilent TPS Turbo Pumping Systems Models

## Agilent TPS-mobile



Roll-around cart, high capacity systems, with higher compression ratio and wide pumping speed range. 14 possible configurations, with Agilent Turbo-V 81 and 301 Navigator pumps, and the new Agilent Turbo-V 750 TwisTorr, & Dry Scroll (New unique IDP-3, SH-110, TS 300/600) or DS Mechanical Pumps. Gauges and accessories available for customized solutions. T-Plus Navigator Software, Isolation valve integrated/included. Voltage 110/230V. CE, UL/CUL, CSA and Semi S2-0200 certified.

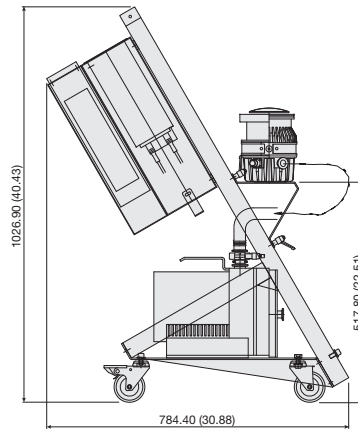

Width: 422 (16.61)

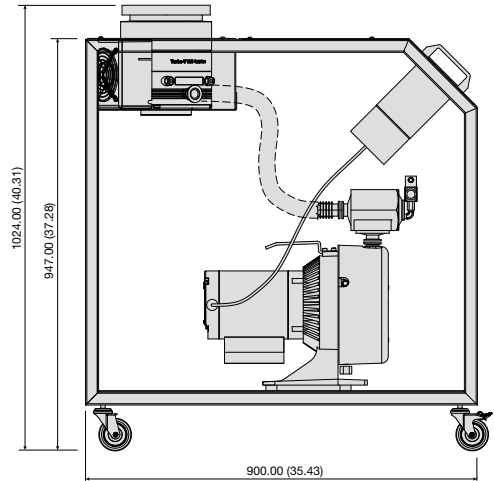

Width: 400 (15.75)

Dimensions: millimeters (inches)

## Agilent TPS-bench



TPS-bench with TV 81M and DS 42

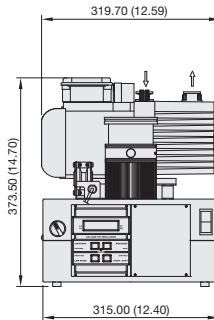

TPS-bench with TV 301 and DS 102

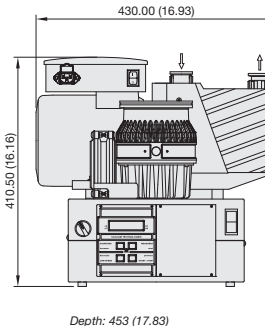

Depth: 453 (17.83)

TPS-bench with TV 301 and SH110

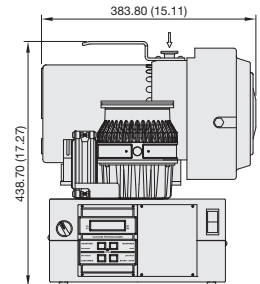

Dimensions: millimeters (inches)

Bench-top, compact and reliable vacuum solutions. 5 possible standard configurations with Turbo-V 81 or Turbo-V 301 Navigator, backed by SH-110 Dry Scroll, DS 42 or DS 102 Rotary Vane Pumps. Gauges and accessories available. T-Plus Navigator Software, and Isolation valve integrated/included. Voltage 110/230V. CE, UL/CUL, CSA and Semi S2-0200 certified.



# TPS Turbo Pumping Systems

## Benefits

- Fast, clean, dry pump down from atmosphere to  $10^{-10}$  mbar
- Pressure monitor
- Portable and compact
- Agilent Turbo Pumps: no maintenance required
- Low cost of ownership

## Applications

- UHV System pump down
- Ion pump roughing
- Lamp and tube processing
- Cryopump regeneration
- High Vacuum Systems operation
- High and Ultra High Vacuum systems bake out

## Turbomolecular Pumps

### Turbo Pump Model Inlet Flange

Turbo-V 81-M Pump ISO 63, KF 40\*, CFF 4 1/2"\*

Turbo-V 301 Navigator Pump ISO 100, CFF 6"\*

Turbo-V 750 TwisTorr ISO CFF 8", 160\*, CFF 6"\*

\* Configuration available on request.

## Primary Pumps

Dry Scroll Pumps	Peak Pumping Speed 50 Hz
IDP-3	3.0 m <sup>3</sup> /h
Single Phase Motor Scroll Pump SH110	90 l/min - 5.4 m <sup>3</sup> /h - 3.3 cfm
TriScroll 300, single phase, with Vacuum Pump Isolation Valve (VPI)	220 VAC 210 l/min 2.6 m <sup>3</sup> /h - 7.4 cfm
TriScroll 600, single phase, with Vacuum Pump Isolation Valve (VPI)	220 VAC 420 l/min 25.2 m <sup>3</sup> /h - 14.8 cfm

### Rotary Vane Dual Stage Pumps Pumping Speed 50 Hz

DS 42 - 1 phase worldwide motor	1.8 m <sup>3</sup> /h
DS 102 - 1 phase worldwide motor	5.0 m <sup>3</sup> /h
DS 302 - 1 phase worldwide motor	11.6 m <sup>3</sup> /h
DS 402 - 1 phase worldwide motor	17.4 m <sup>3</sup> /h

## Turbomolecular Pumps - Pumping Speed l/sec

	TV 81M		TV 301 Nav		TV 750 TwisTorr	
	DN 40*	DN 63	DN 100	DN 160*	DN 100*	DN 160
Nitrogen	50	77	250	280	370	700
Helium	56	65	220	230	500	680
Hydrogen	46	50	200	210	470	580

\* Configuration available on request.

## Recommended Forepumps

	TV 81M	TV 301	TV 750 TwisTorr
Primary Pumps Dry	SH110, IDP-3	SH110, IDP-3, TS 300 VPI	TS 300 VPI, TS 600 VPI
Primary Pumps Mechanical	DS 42 - DS 102	DS 102, DS 302, DS 402	DS 302, DS 402

## Base Pressure with Recommended Forepump - Acc. to standard DIN 28 428

	TV 81M	TV 301	TV 750 TwisTorr
Primary Pumps Dry	$5 \times 10^{-9}$ mbar ( $3.8 \times 10^{-9}$ Torr)	$< 5 \times 10^{-9}$ mbar ( $< 3.75 \times 10^{-9}$ Torr)	$< 1 \times 10^{-10}$ mbar ( $< 7.5 \times 10^{-11}$ Torr)
Primary Pumps Mechanical	$5 \times 10^{-10}$ mbar ( $3.8 \times 10^{-10}$ Torr)	$< 5 \times 10^{-10}$ mbar ( $< 3.75 \times 10^{-10}$ Torr)	$< 1 \times 10^{-10}$ mbar ( $< 7.5 \times 10^{-11}$ Torr)

## TPS-mobile: 14 possible standard configurations

TMP	DS42	DS102	DS302	DS402	IDP3	SH110	TS300	TS600
TV 81M	•	•			•	•		
TV 301		•	•	•	•	•	•	
TV 750			•	•			•	•

## TPS-bench: 5 possible standard configurations

TMP	DS42	DS102	SH110
TV 81M	•		•
TV 301		•	•

# Agilent TPS Turbo Pumping Systems Models

## Agilent TPS-mobile and TPS-bench

### Ordering Information

#### TPS-mobile 110 V

Turbo-V Pump	Flange	Forepump	Part Number
TV81M	ISO63	DS42	9698420
TV81M	ISO63	DS102	9698421
TV81M	ISO63	IDP3	9698422
TV81M	ISO63	SH110	9698423
TV301	ISO100	DS102	9698424
TV301	ISO100	DS302	9698425
TV301	ISO100	DS402	9698426
TV301	ISO100	IDP3	9698427
TV301	ISO100	SH110	9698428
TV301	ISO100	TS300VPI	9698429
TV750	CFF8	DS302	9698439
TV750	CFF8	DS402	9698440
TV750	CFF8	TS300VPI	9698441
TV750	CFF8	TS600VPI	9698442

Other configurations available on request.

#### TPS-bench 110 V

Turbo-V Pump	Flange	Forepump	Part Number
TV301	ISO100	SH110	9698212
TV301	ISO100	DS102	9698213
TV81M	ISO63	DS102	9698214
TV81M	ISO63	SH110	9698215
TV81M	ISO63	DS42	9698216

Other configurations available on request.

#### TPS-mobile 220 V

Turbo-V Pump	Flange	Forepump	Part Number
TV81M	ISO63	DS42	9698413
TV81M	ISO63	DS102	9698411
TV81M	ISO63	IDP3	9698416
TV81M	ISO63	SH110	9698412
TV301	ISO100	DS102	9698403
TV301	ISO100	DS302	9698400
TV301	ISO100	DS402	9698417
TV301	ISO100	IDP3	9698418
TV301	ISO100	SH110	9698402
TV301	ISO100	TS300VPI	9698401
TV750	CFF8	DS302	9698435
TV750	CFF8	DS402	9698436
TV750	CFF8	TS300VPI	9698437
TV750	CFF8	TS600VPI	9698438

Other configurations available on request.

#### TPS-bench 220 V

Turbo-V Pump	Flange	Forepump	Part Number
TV301	ISO100	SH110	9698203
TV301	ISO100	DS102	9698208
TV81M	ISO63	DS102	9698204
TV81M	ISO63	SH110	9698202
TV81M	ISO63	DS42	9698200

Other configurations available on request.

### Managing Gauges

GAUGE KIT	Inlet Flange	DIY FRG-700 Full Range Gauge Kit (atmosphere to $3.8 \times 10^{-9}$ Torr)
TV 81M	KF 40	9699190
	ISO 63	9699192
	CFF 4½"	9699193
TV 301	ISO 100	9699194
	CFF 6"	9699201
TV 750 TwisTorr	ISO 160 K	9699195
	CFF 6"	9699201
	CFF 8"	9699202

For other gauge configurations, please contact your local Agilent representative.

### Cables

Power cords are included free of charge in all TPS-bench and TPS-mobile models, with US, EU or UK plug.